

AT90S35PB Project Board

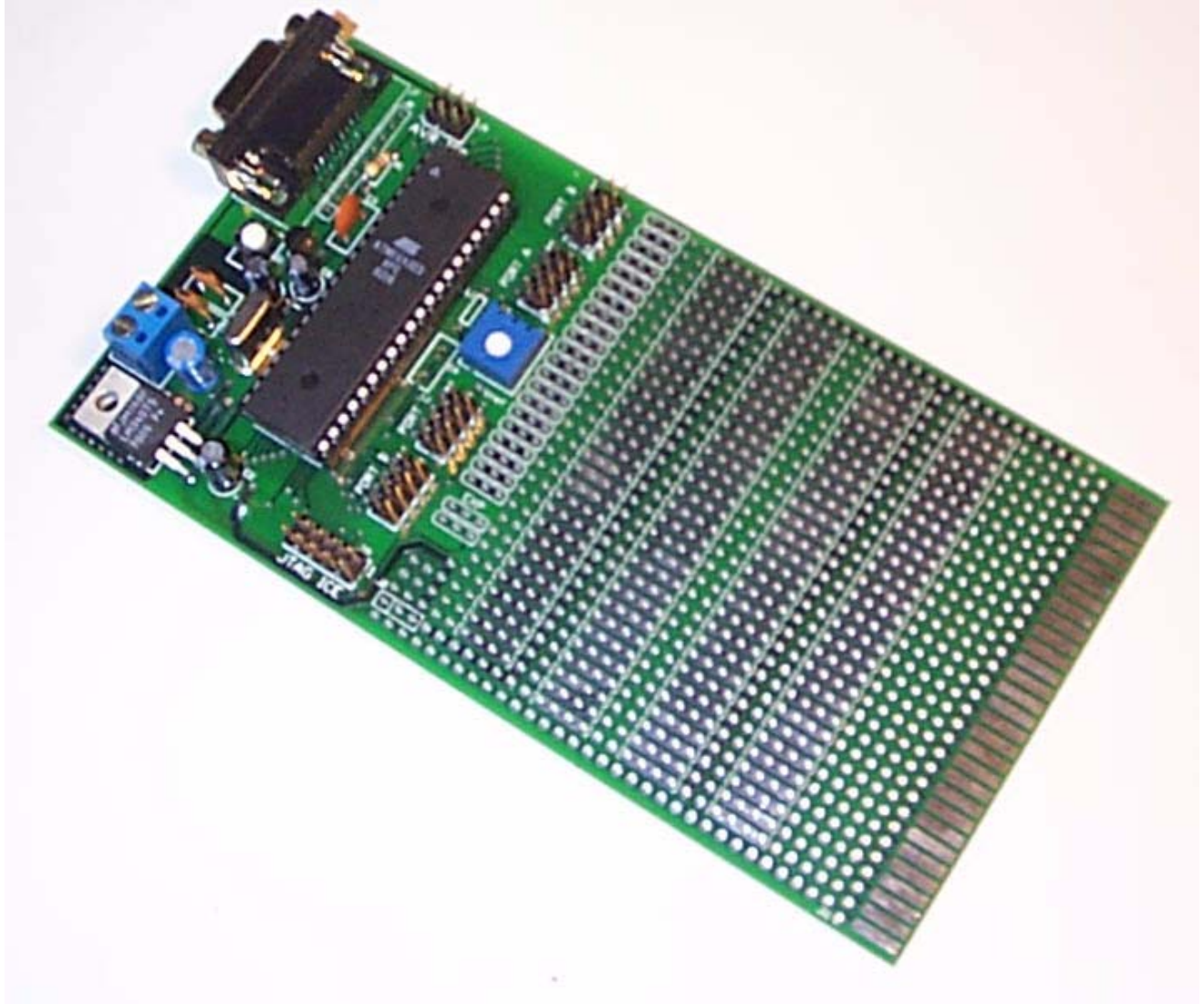

vayan
Electronics

AT90S35PB AVR 8 bit RISC Microcontroller Project Board

This is the project board many AVR enthusiasts have been looking for. It will allow hobbyists and professionals to build their application fast whether it is soldered or wire wrapped. Compatible with most of the 40 pin devices from Atmel 8-bit RISC architecture microcontrollers, the user can develop applications on microcontrollers such as AT90S8535, ATMEGA8535, ATMEGA 16, ATMEGA163, ATMEGA32 and ATMEGA323.

The board comes ready to use with all the necessary support components such as an 8MHz crystal working as external oscillator, a voltage monitor for Brown Out Detection, JTAG In Circuit Emulation port, ISP port for in circuit programmability, 5V voltage regulator good up to 1 Amp, reset button, header male connectors for all available ports (PORTA, PORT B, PORTC and PORTD) and the layout of a serial port female DB9 connector in case interface to the PC through the RS232 port is desired (NOTE: User must supply line level converter for RS232 communications).

A huge prototyping area with bus connections will make concepts come to reality in a snap. To add flexibility to future designs, the bottom edge of the AT90S35PB is a male edge connector perfect for adding these prototype boards to a back plane such as the Project Board Mother Board (PMB).

The AT90S35PB board is divided into four main sections: Microcontroller Unit Section, Port Section, Prototyping section and the Edge Connector Section.

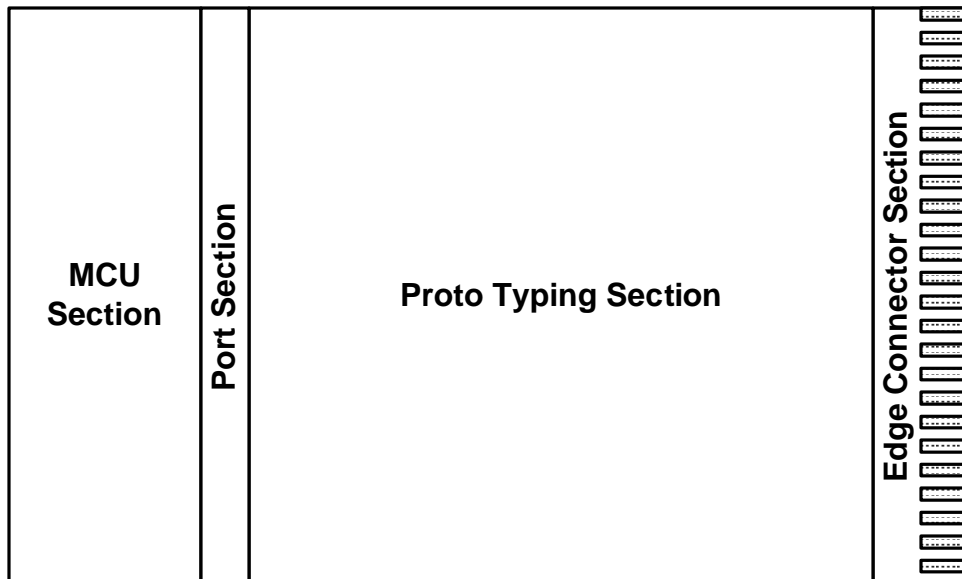

AT90S35PB AVR 8 bit RISC Microcontroller Project Board

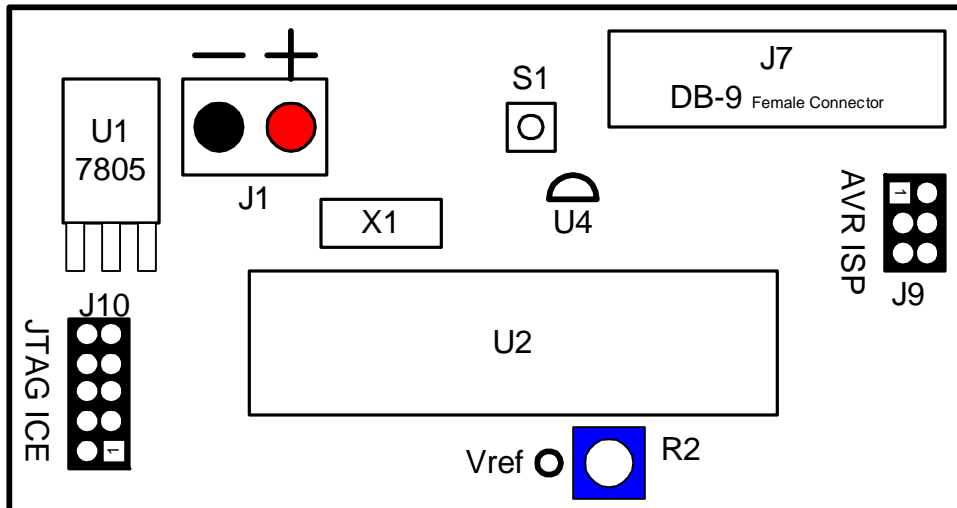

MCU Section:

This portion of the board contains the necessary circuitry to properly connect one ATMEL AVR microcontroller. U2 is a socket accepting a 40 pin device such as the AT90S8535, ATMEGA8535, ATMEGA16, ATMEGA163, ATMEGA32 and ATMEGA323.

Power Connector: A two circuit high current terminal block is used to power the board with a source ranging from 6 to 24V. Pin 1 is V+ while pin 2 is V- (ground return). An LM7805 voltage regulator regulates the input voltage into a good VCC = 5V source that powers the devices for up to 1 Amp rated current. Because this board is diode protected, connecting the power backwards will not result in board damage.

Reset Manager: Some AVR microcontrollers do not have brown out detectors. To allow proper functioning, the AT90S35PB includes an MC34064 voltage monitor. U4 will make sure the reset line remains high unless insufficient power is being administered to the board. Also, the S1 button will pull down the reset line generating a reset.

ISP Programming: An individual ISP connector is provided so that the firmware code can be downloaded into the respective microcontroller. J9 is the ISP connector for the 40 pin device on U2. Simply connect your ATAVRISP programmer into J9, with the red stripe pointing towards pin 1, and the device is ready to be programmed. If ISP related pins in the target board (AT90S35PB with a prototyped application) have been connected to a load, make sure this load does not work against the programming signals.

AT90S35PB AVR 8 bit RISC Microcontroller Project Board

Microcontroller Section: (Cont.)

JTAG In Circuit Emulator: Some microcontrollers such as the ATMEGA16, ATMEGA32 and ATMEGA323 contain 4 pins used to program and debug the chip in circuit. The JTAG connector, J10, allows the AVR JTAG ICE device to be plugged into the application gaining visibility to all internal resources. Make sure the four communication lines are not being adversely driven by the application on the prototype area.

Potentiometer R2: The variants of the AT90S8535 microcontroller have an 8 channel Analog to Digital Converter. To properly set the analog reference voltage, pot R2 has been provided. Also, a test hole called Vref is located very close to the potentiometer allowing to probe this voltage.

Serial Communication Port: Some projects require serial communication from the RS232 port found on conventional PC's. A female DB9 connector is provided so that the user can add serial communication capability. Have in mind that it is still the responsibility of the user to add RS232 line drivers in case the data comes from an RS232 compliant port. For TTL serial data, no line driver is needed.

Oscillators: A crystal is provided to work as system oscillator for each microcontroller. The AT90S15PB usually ships with an 8 MHz crystal but other frequency resonators can be installed as well.

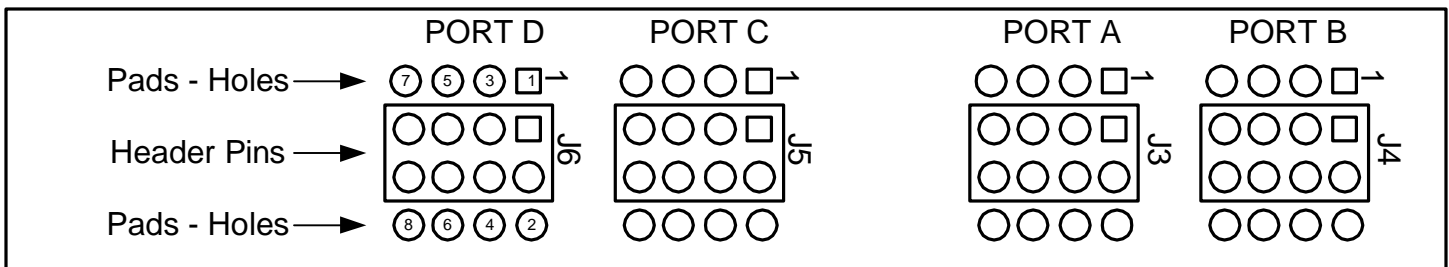

Port Section:

To ease the peripheral connection to the microcontrollers, all ports have been extended to a header pin slot as well as to a pad sector. The header connector allow for other connectors to be plugged directly into the board and also helps to do wire wrapping style of prototyping. The pads will allow to solder a connection from the port into another area such as prototyping or edge connector sections.

J6 corresponds to PORT D, J5 to PORT C, J3 to PORT A and J4 to PortB. Each port has pin #1 as a square pad. Per example, pin 1 on PORT B would correspond to PORT B Pin 0 or PB0. Pin order has been shown on J6. All other connectors observe the same pin order.

AT90S35PB AVR 8 bit RISC Microcontroller Project Board

Prototyping Section:

Some space is allocated to add the extra circuitry that will make up the target system, in the form of a pad grid. There are close to a 1000 pads carefully arranged in the mentioned area. A power bus runs through the prototype grid allowing easy access to VCC and GND lines. The grid was designed to allow components such as through hole DIP IC's, resistors, capacitors, transistors, etc.

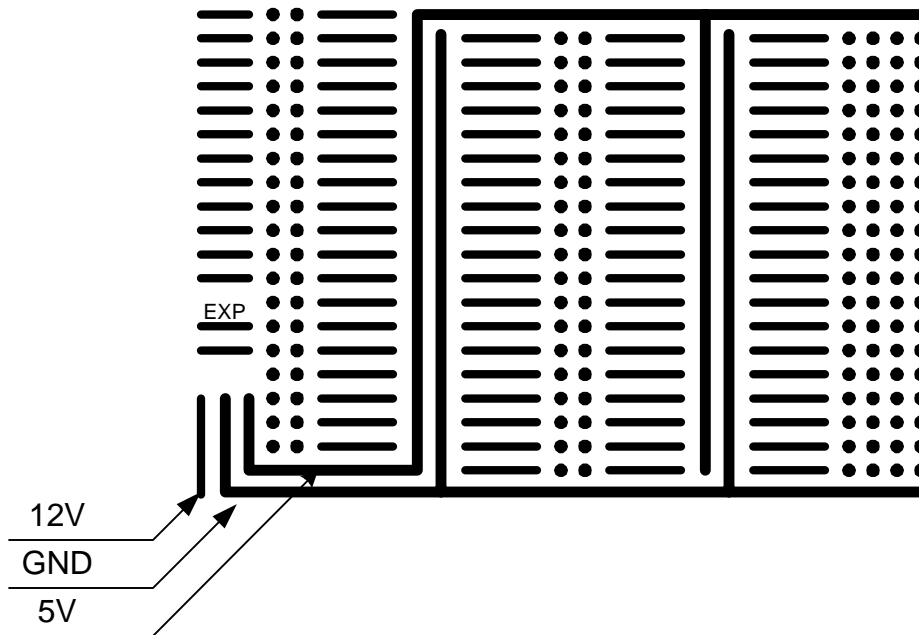

Prototype Diagram: Not exact amount of pads shown

The prototyping area has been designed with power distribution in mind. One small segment contains the voltage in (same voltage being connected at J1). Ground and VCC follows. The idea with these copper strips is to allow the user add extra 7805 voltage regulators in case more amperage is needed. Also it adds the capability to use input voltage to power up prototypes circuitry.

Expansion Sub-Section:

Marked by EXP, an extra set of pads will allow the user to interface directly to the reset, XTAL IN and XTAL OUT lines. The idea is to allow projects to deal with the reset signal at the same time the external oscillator on the 40 pin device can be used to synchronization purposes. XTAL IN is the rectangular pad (pad 1), XTAL OUT is the octagonal pad (pad 2), and reset is the circular pad (pad 3).

AT90S35PB AVR 8 bit RISC Microcontroller Project Board

Expansion Section: (Cont.)

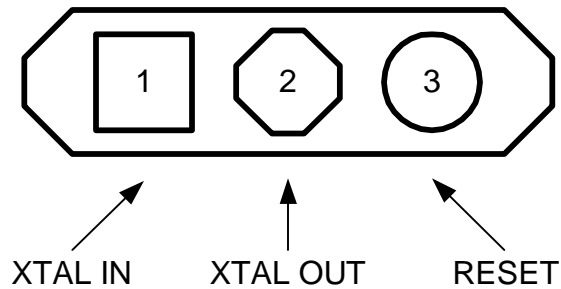

Edge Connector Section:

Expandability is not a problem with the AT90S35PB thanks to the edge connector on the bottom edge of the board. Up to 62 different signals can be brought into or from the board by means of standard 62 pin, 100 mil from pin to pin edge connector. Avayan Electronics' MBPB-3 is a good example of a 3 edge connector mother board that will supply power, communication and control signals between three edge connector based boards.

Each tab on the edge connector, is connected to a pad. The user must connect input and output signals from this set of pads into any other pad located at the prototype section or the port section.

These pads connect to the bottom side edge pads
These pads connect to the top side edge pads

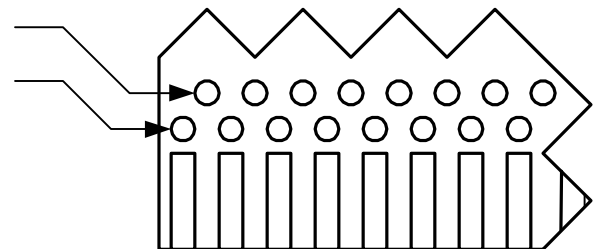

AT90S35PB AVR 8 bit RISC Microcontroller Project Board

AT90S35PB Schematic

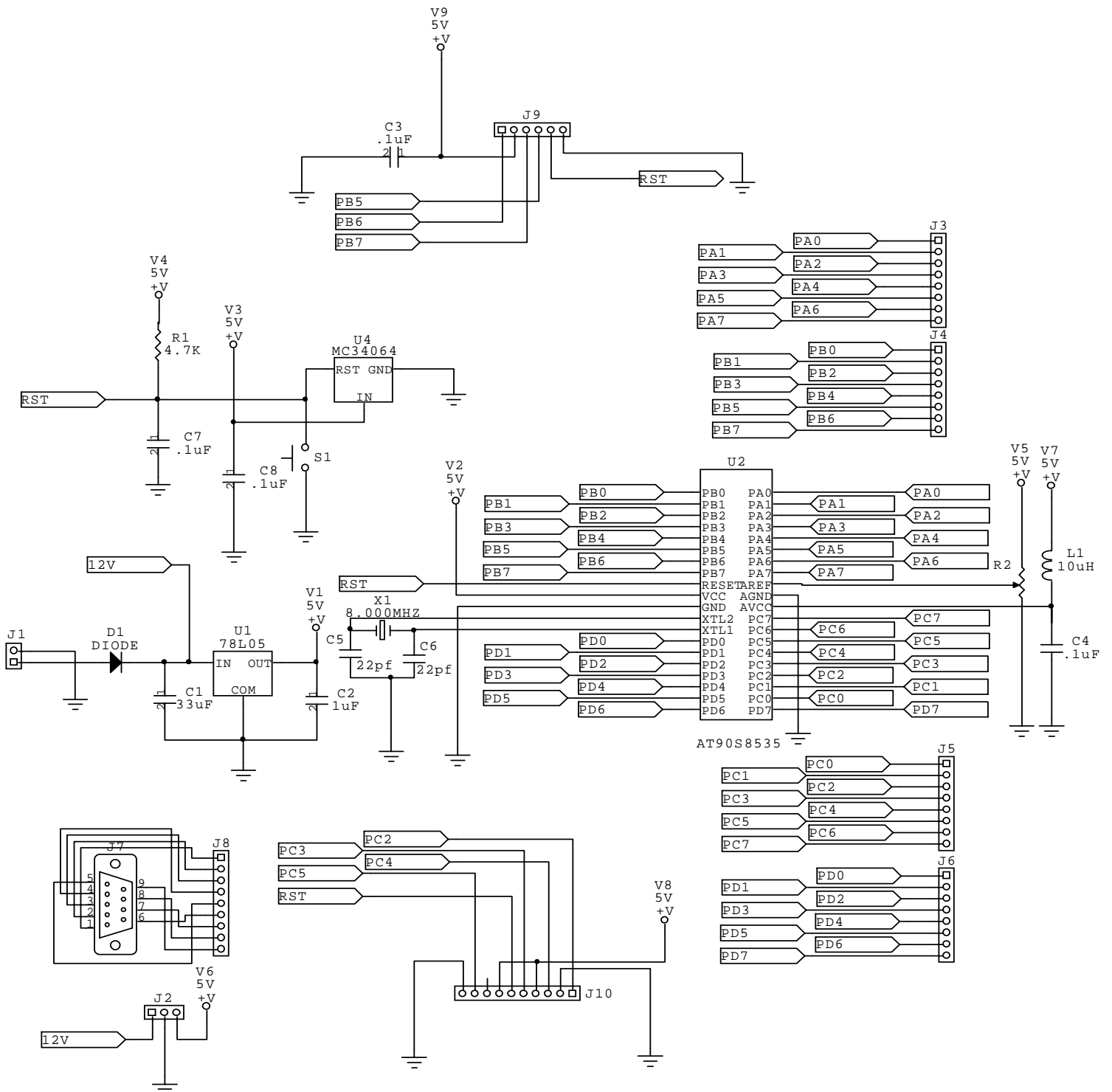

AT90S35PB AVR 8 bit RISC Microcontroller Project Board

AT90S35PB Bill Of Materials (BOM):

Item	Count	Label-Value	PACKAGE	Designation
1	1	33uF	Electrolytic	C1
2	1	1uF	Electrolytic	C2
3	4	.1uF	Ceramic Disc	C3,C4,C7,C8
4	2	22pf	Ceramic Disc	C5,C6
5	1	CONN	Terminal Block 2	J1
6	1	CONN	SIP3	J2
7	4	CONN	IDC8	J3,J4,J5,J6
8	1	CONN	DB9/F	J7
9	1	CONN	SIP9	J8
10	1	CONN	IDC6	J9
11	1	CONN	IDC10	J10
12	1	10uH	AXIAL0.3	L1
13	1	4.7K	RAD0.2	R1
14	1	10k var	Square Pot	R2
15	1	Switch	LTS_Pan_2C	S1
16	1	78L05	TO-220	U1
17	1	AT90S8535	DIP40	U2
18	1	MC34064	TO-92C	U4
19	1	8.000MHZ	RAD0.2	X1
20	1	SOCKET	DIP40	SK1
21	1	Diode	RB.1/.2	D1

AT90S35PB AVR 8 bit RISC Microcontroller Project Board

AT90S35PB Kit Assembly Instructions:

Thank you for purchasing an Avayan Electronics' Evaluation/Project Board. We hope the tools satisfy you into making easy developing ideas. Please follow the next instructions when assembling your kit:

What you will need:

1. Soldering iron with fine point. 30W recommended.
2. Solder tin
3. (Optional) Board Vise

1. Make sure your kit contains all the components as specified by the BOM sheet.
2. Place and solder all thru hole components.

SOLDERING HINT: Place all thru hole components first and then from the board bottom, solder one of the component pins. Once every component has at least a soldered pin you can turn the board into the other side making it easier to solder the remaining pins (extremely helpful when soldering more than two pin parts). If it is hard to position the board in such a way that both bottom and top are accessible at the same time, solder each component as you go through the following steps.

- a. Position the 33 uf cap into C1. Please observe polarity. The plus sign on the silk screen should match the plus sign on the capacitor.
- b. Position the 1 uf cap into C2 observing proper polarity.
- c. Position .1 uf ceramic capacitors on C3, C4, C7 and C8.
- d. Position the two 22 uf ceramic capacitors on C5 and C6.
- e. Position the two circuit Terminal Block (blue plastic connector) into J1.
- f. If you desire to have access to the 12V, 5V and Ground plane through test stakes, place the three circuit header connector on J2. This connector space is actually designed to add an optional 7805 voltage regulator in case the 5V plane needs more than 1A current.
- g. Position the eight circuit dual row header connector on J3 (PORTA), J4 (PORTB), J5 (PORTC), and J6 (PORTD).
- h. Position the DB9 female connector on J7 as well as the 9 circuit header connector (SIP9) on J8 to gain access to serial ports.
- i. Position the six circuit dual row header connector on J9 (ISP Port).
- j. Position the ten circuit dual row header connector on J10 (JTAG ICE Port).
- k. Position the 10 uH inductor on L1. This part is usually green and color coded brown-black-black-gold.
- l. Position the 4.7K resistor on R1. This resistor is color coded Yellow-Purple-Red-Gold.

AT90S35PB AVR 8 bit RISC Microcontroller Project Board

AT90S35PB Kit Assembly Instructions (Cont.):

- m. Position the 10K Potentiometer on R2. This potentiometer is a blue square single turn pot.
- n. Position the switch on S1. You may need to trim the leads before inserting the pin into the holes.
- o. Position the LM7805 voltage regulator into U1. Bend the leads so that the regulator back lies at the heat sink square pad. At the end of the assembly it would be a good idea to solder the back of the regulator on this pad to improve heat dissipation. Have patience as soldering such a large pad takes time.
- p. Position the 40 pin socket on U2.
- q. Position the Reset Manager MC34064 on U4. Notice that the oval shape must correspond to that on the silk screen or else the part will be reverse polarized.
- r. Position the 8.00 MHz (or any other desired for your particular project) on X1.
- s. Position the 1n4003 diode on D1