

Basic Stamp I and II Project Board

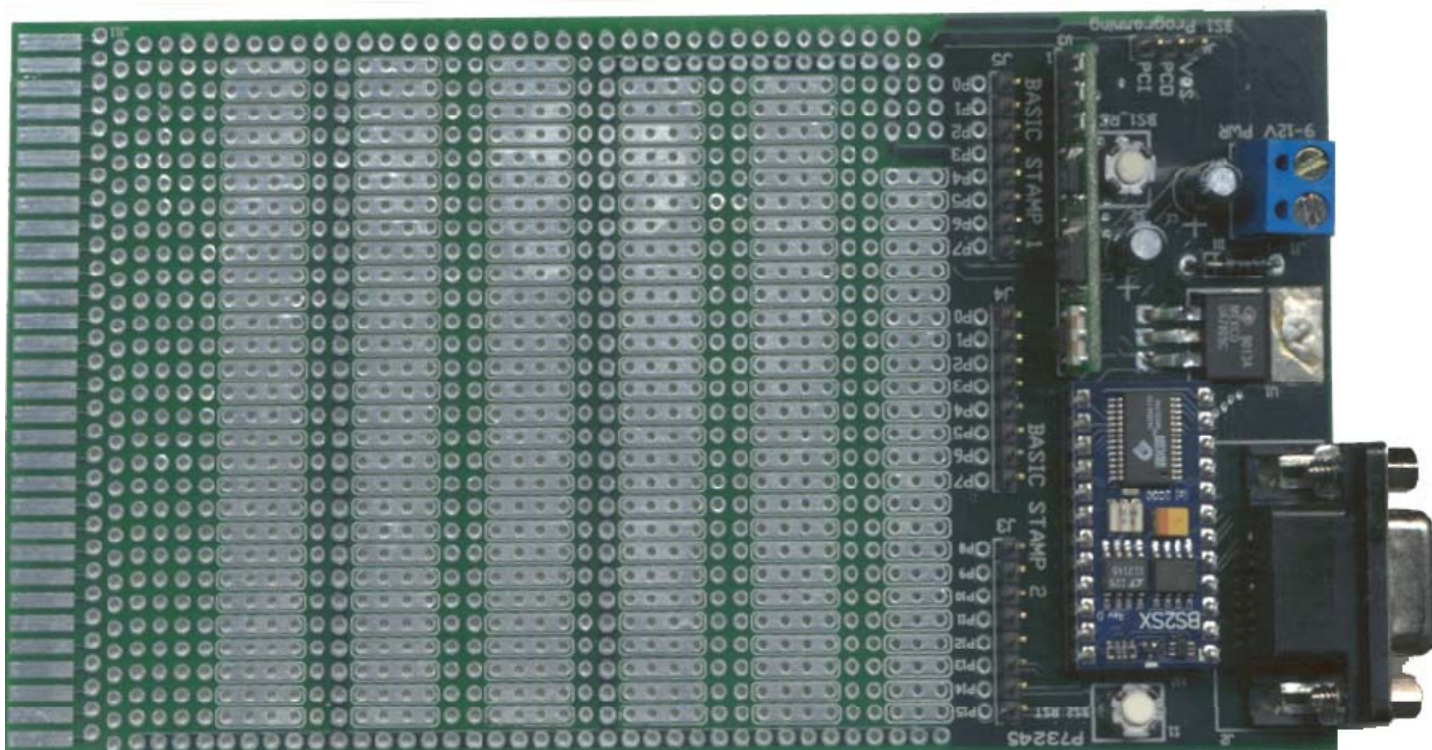

Basic Stamp I and II Single Board Computer Project Board

This is the board all Basic Stamp users have been waiting for. It will allow hobbyist and professionals to build their application fast whether it is soldered or wire wrapped. Compatible with all BASIC Stamp I and all BASIC Stamp II single board computers, the user can take advantage of all the embedded resources at the same time all tedious connections are supplied for convenience.

The board comes ready to use with all the necessary support components such as serial programming ports for both Stamp styles, 5V voltage regulator good up to 1 Amp, a reset button per unit, header male connectors for all available ports (P0-P7 in BASIC Stamp I modules and P0-P15 in BASIC Stamp II modules)

A huge prototyping area with bus connections will make concepts come to reality in a snap. To add flexibility to future designs, the bottom edge of the BSPB is a male edge connector perfect for adding these prototype boards to a back plane such, as the Project Board Mother Board (PBMB).

The BSPB board is divided into four main sections: Single Board Computer Section, Ports Section, Prototyping section and the Edge Connector Section.

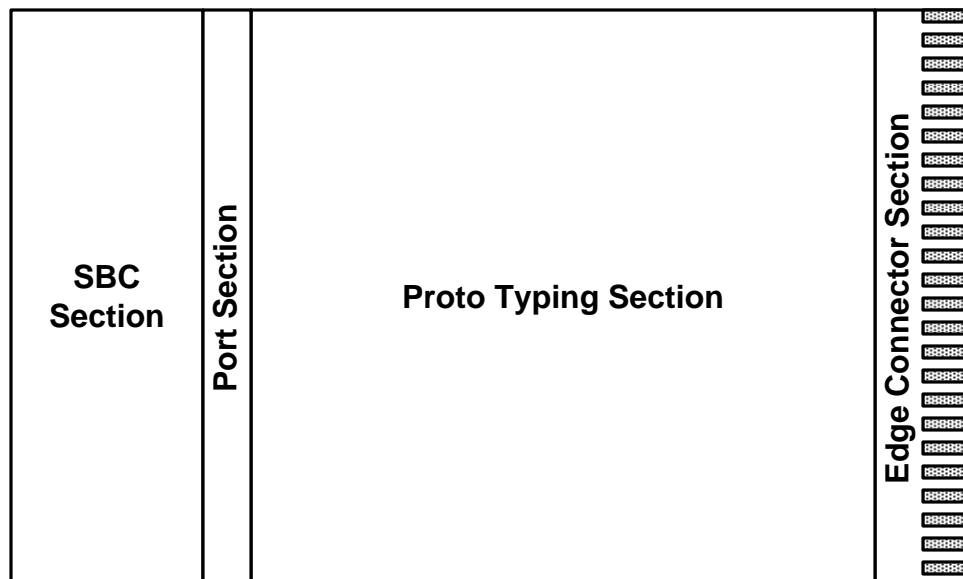

Basic Stamp I and II Single Board Computer Project Board

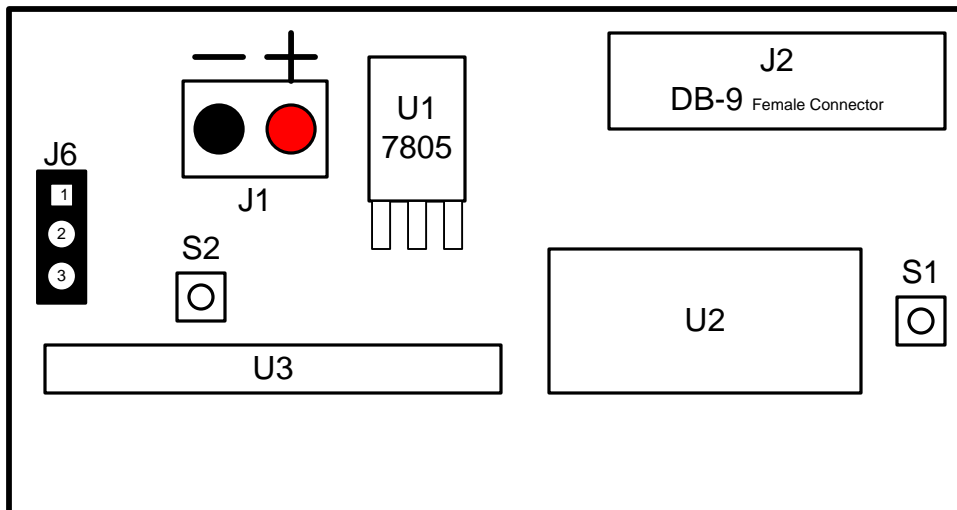

SBC Section:

This portion of the board contains the necessary circuitry to properly connect one BASIC Stamp I module and a BASIC Stamp II module at the same time if desired. U2 is a socket accepting a 24 pin device such as the BS2, BS2P, BS2E, BS2SX, BS2PE, or any other compatible Stamp 24 pin module. U3 will accept the BASIC Stamp I module.

Power Connector: A two circuit high current terminal block is used to power the board with a source ranging from 6 to 18V. Pin 1 is V+ while pin 2 is V- (ground return). An LM7805 voltage regulator regulates the input voltage into a good VCC = 5V source that powers the devices for up to 1 Amp rated current. Because this board is diode protected, connecting the power backwards will not result in board damage.

Programming Ports: Each module contains its own programming port. BASIC Stamp I modules enjoy the typical three wire connector at J6. For BASIC Stamp II modules, J2 is a female DB9 connector accepting a conventional 9 pin serial cable connected to a PC COMM Port.

Reset Buttons: Each SBC module contains its own reset button. This button is extremely useful when wanting to start the programmed application from the starting point. S1 works as a reset button to the BASIC Stamp I module while S2 works as a reset button for the BASIC Stamp II module.

Basic Stamp I and II Single Board Computer Project Board

Port Section:

To ease the peripheral connection to the microcontrollers, all ports have been extended to a header pin slot as well as to a pad sector. The header connector allow for other connectors to be plugged directly into the board and also helps to do wire wrapping style of prototyping. The pads will allow to solder a connection from the port into another area such as prototyping or edge connector sections.

J6 corresponds to PORT D, J5 to PORT C, J3 to PORT A and J4 to PortB. Each port has pin #1 as a square pad. Per example, pin 1 on PORT B would correspond to PORT B Pin 0 or PB0. Pin order has been shown on J6. All other connectors observe the same pin order.

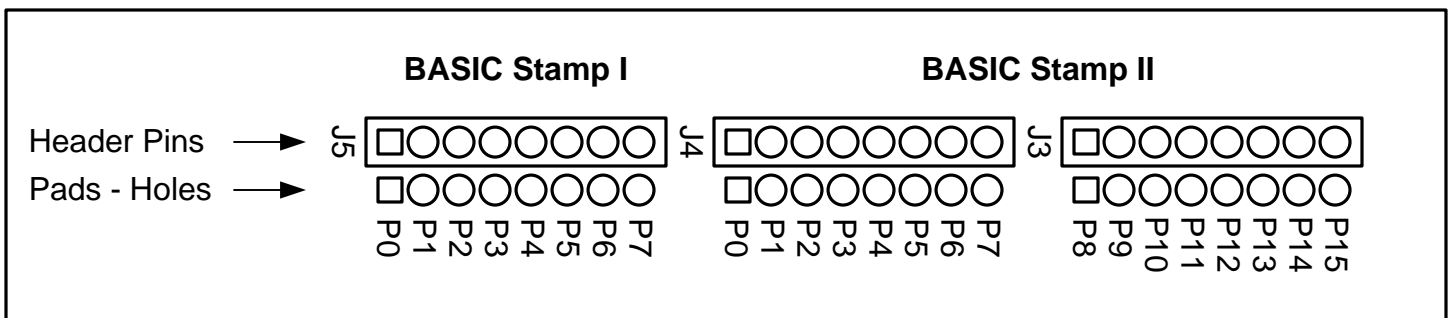

Basic Stamp I and II Single Board Computer Project Board

Prototyping Section:

Some space is allocated to add the extra circuitry that will make up the target system, in the form of a pad grid. There are close to a 1000 pads carefully arranged in the mentioned area. A power bus runs through the prototype grid allowing easy access to VCC and GND lines. The grid was designed to allow components such as through hole DIP IC's, resistors, capacitors, transistors, etc.

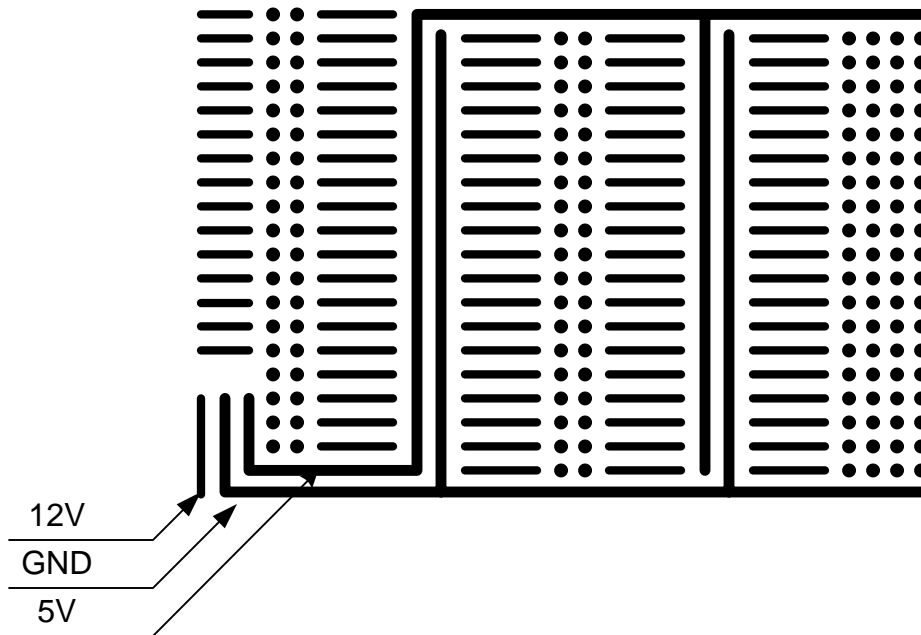

Prototype Diagram: Not exact amount of pads shown

The prototyping area has been designed with power distribution in mind. One small segment contains the voltage in (same voltage being connected at J1). Ground and VCC follows. The idea with these copper strips is to allow the user add extra 7805 voltage regulators in case more amperage is needed. Also it adds the capability to use input voltage to power up prototypes circuitry.

Basic Stamp I and II Single Board Computer Project Board

Edge Connector Section:

Expandability is not a problem with the AT90S35PB thanks to the edge connector on the bottom edge of the board. Up to 62 different signals can be brought into or from the board by means of standard 62 pin, 100 mil from pin to pin edge connector. Avayan Electronics' MBPB-3 is a good example of a 3 edge connector mother board that will supply power, communication and control signals between three edge connector based boards.

Each tab on the edge connector, is connected to a pad. The user must connect input and output signals from this set of pads into any other pad located at the prototype section or the port section.

These pads connect to the bottom side edge pads

These pads connect to the top side edge pads

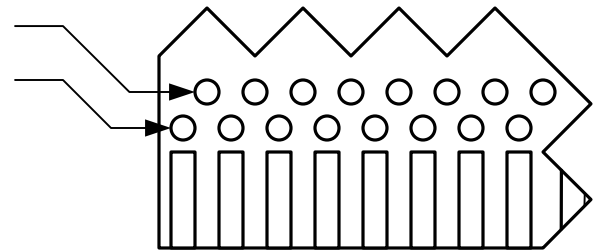

Basic Stamp I and II Single Board Computer Project Board

BSPB Schematic

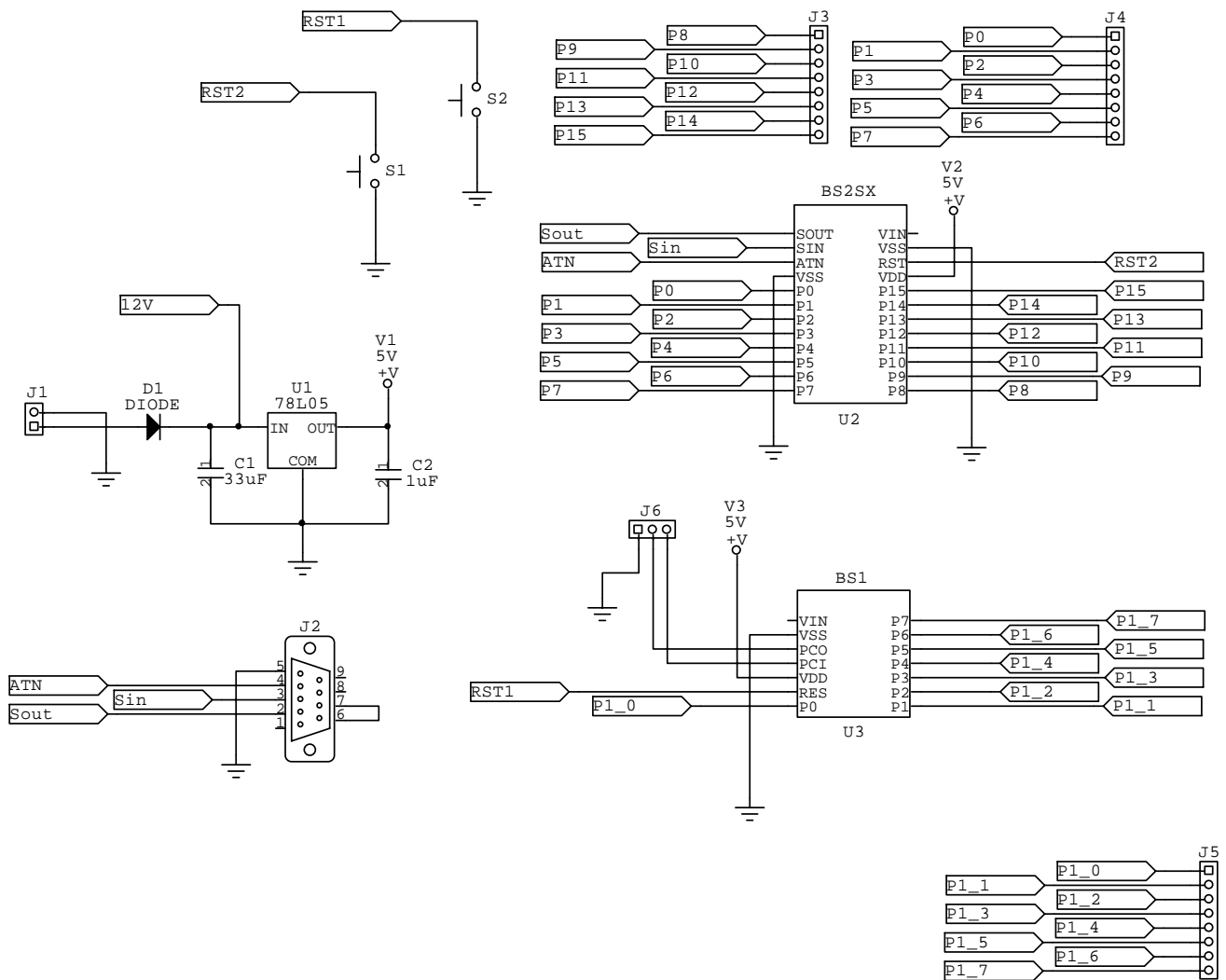

Basic Stamp I and II Single Board Computer Project Board

BSPB Bill Of Materials (BOM):

Item	Count	Description	Ref Des
1	1	33uF	C1
2	1	1uF	C2
3	1	1N4003	D1
4	1	SIP2 Connector	J1
5	1	DB9/F Connector	J2
6	3	IDC8 Connector	J3,J4,J5
7	1	SIP3 Connector	J6
8	2	Switch	S1,S2
9	1	78L05	U1
10	1	DIP24	U2
11	1	SIP14	U3

Basic Stamp I and II Single Board Computer Project Board

BSPB Kit Assembly Instructions:

Thank you for purchasing an Avayan Electronics' Evaluation/Project Board. We hope the tools satisfy you into making easy developing ideas. Please follow the next instructions when assembling your kit:

What you will need:

1. Soldering iron with fine point. 30W recommended.
2. Solder tin
3. (Optional) Board Vise

1. Make sure your kit contains all the components as specified by the BOM sheet.
2. Place and solder all thru hole components.

SOLDERING HINT: Place all thru hole components first and then from the board bottom, solder one of the component pins. Once every component has at least a soldered pin you can turn the board into the other side making it easier to solder the remaining pins (extremely helpful when soldering more than two pin parts). If it is hard to position the board in such a way that both bottom and top are accessible at the same time, solder each component as you go through the following steps.

- a. Position the 33 uf cap into C1. Please observe polarity. The plus sign on the silk screen should match the plus sign on the capacitor.
- b. Position the 1 uf cap into C2 observing proper polarity.
- c. Position the 1N4003 diode into D2.
- d. Position the two circuit Terminal Block (blue plastic connector) into J1.
- e. Position the DB9 female connector on J2.
- f. Position the eight circuit single row header connector on J3, J4 and J5.
- g. Position the three circuit single row header connector on J6.
- h. Position the two switches on S1 and S2. You may need to trim the leads before inserting the pin into the holes.
- i. Position the LM7805 voltage regulator into U1. Bend the leads so that the regulator back lies at the heat sink square pad. At the end of the assembly it would be a good idea to solder the back of the regulator on this pad to improve heat dissipation. Have patience as soldering such a large pad takes time.
- j. Position the 24 pin socket on U2.
- k. Position the 14 pin socket on U3.