

PBMB Project Board Mother Board

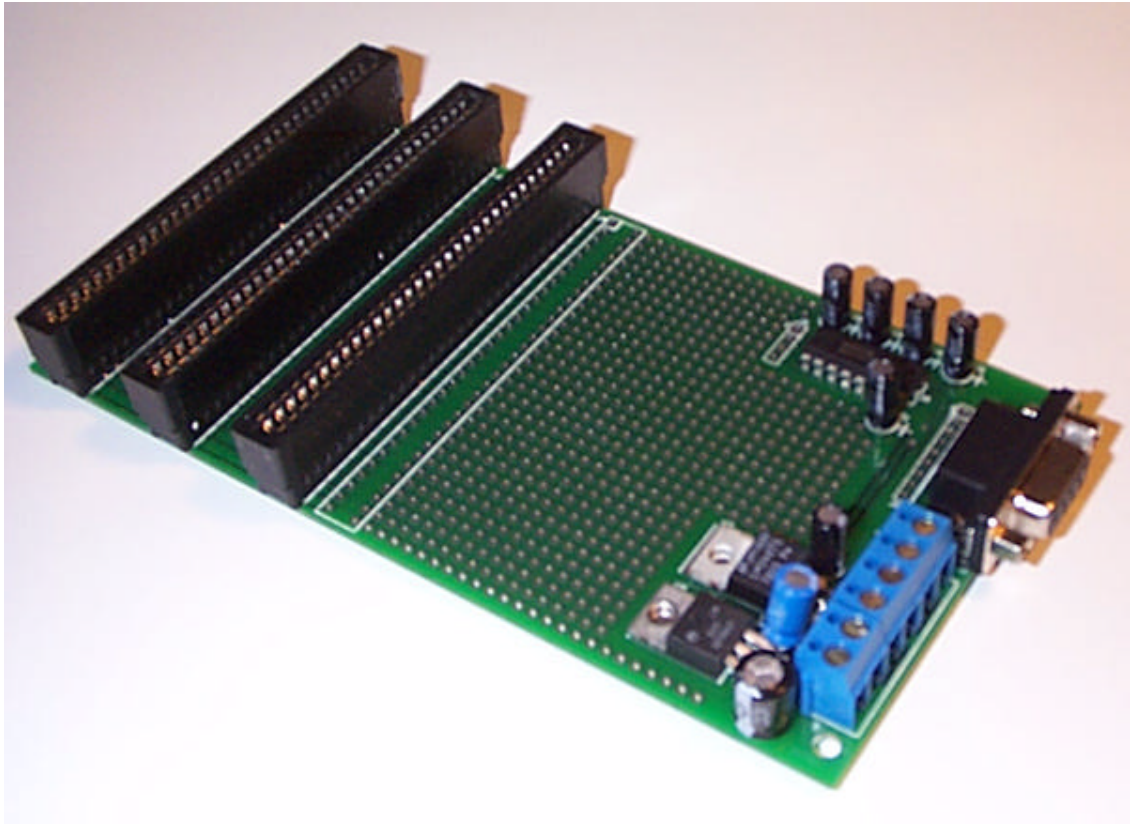

vayan
Electronics

PBMB Project Board Mother Board

Avayan Electronics' Project Boards can now be nested to add more power to your embedded system or robotic application. Using conventional edge card slot connectors, a bus has been devised that will allow up to three of our project boards to share resources such as power, serial communication or whatever other signal the user wishes to interconnect. The board is generic and the prototyping area allows the user to distribute the I/O as needed.

The three edge connectors share 62 lines with a fourth set of parallel lines than can be used to interface them with the prototyping area. A MAX232 driver already incorporates RS-232 to TTL level conversion for data coming from the serial port at the top right corner. 24V or 12V can be administered to the board which will generate 5V up to 1A to power up logic. A good prototyping area ensures easiness at project development time.

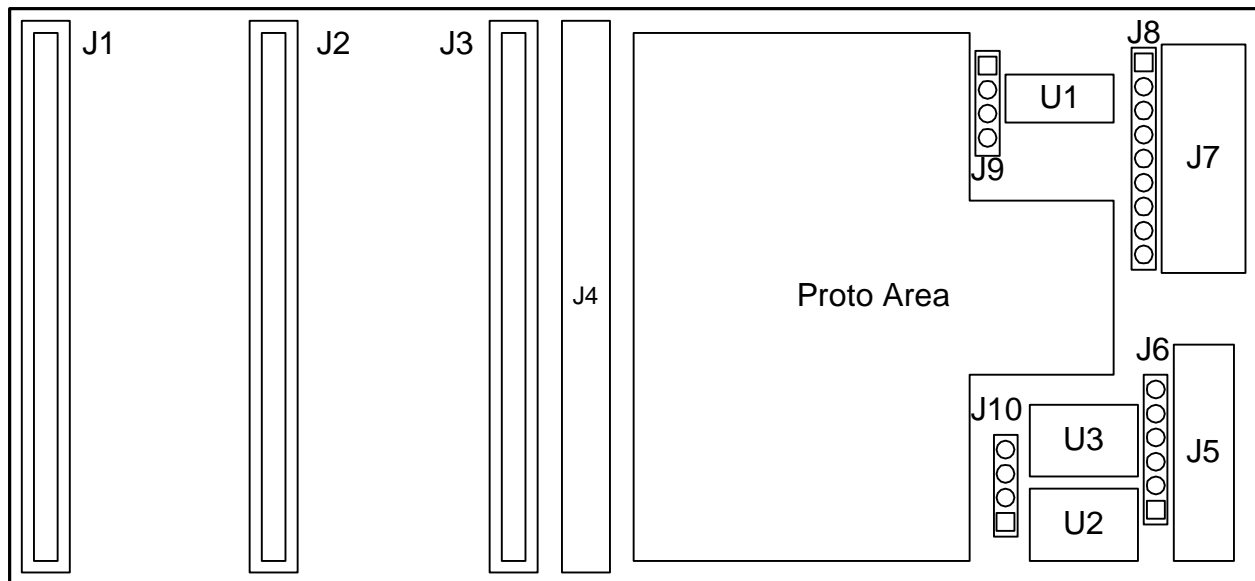

PBMB Project Board Mother Board

J1 to J4: J1 to J3 are edge connectors which accept 62 pin, .100 inch spacing edge slot cards such the project boards. J4 is not populated in order to allow an access point from the power, serial communication and prototype areas. Users can connect any signal to any of the 62 pins. However, have in mind that each pin is rated at a maximum of 1 Amp. If a larger current rating is needed, more pins could be tied together (in parallel) to increase current drive capabilities.

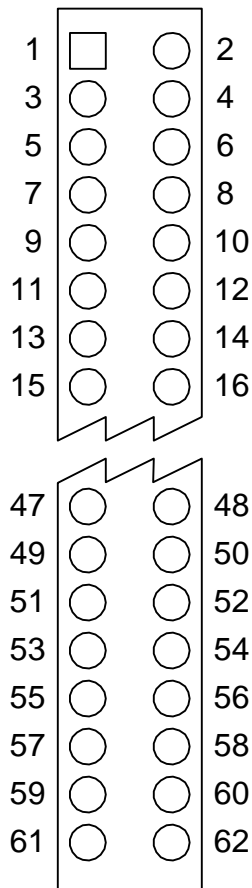

PBMB Project Board Mother Board

J5, J6 and J10 Power Connectors: These three connectors are access points to the input power. J5 is a 6 position terminal block which accepts 24V, 12V and 5V. The board will work if only 24V is applied as 12V and 5V are generated by means of voltage regulators U2 and U3. 24V input is protected against backward connection, however, 12V and 5V are not.

J6 is a good access points to the three voltage levels and the three ground returns. J10 is another good access point for the three voltages with only one ground return. The user could solder header pins to J6 and J10 if wire wrapping style of prototyping is desired. The pinout is shown below.

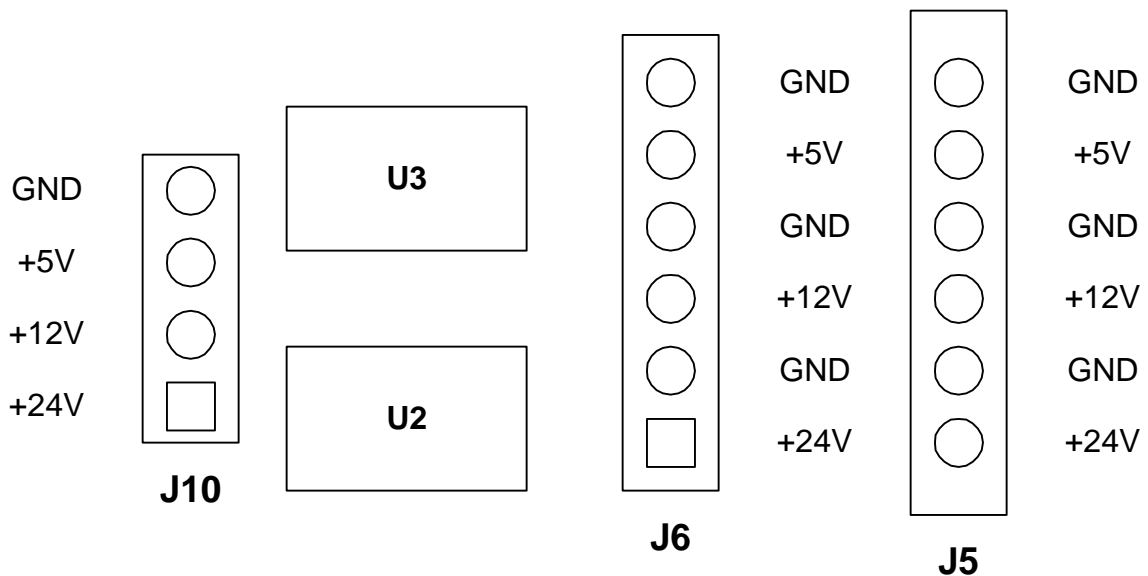

What can be done on J5: Use only 24V and generate internal to the board 12V and 5V. Use only 12V and generate internal to the board 5V. Use only 5V.

What should not be done on J5: Plug with reverse bias 5V or 12V input.

PBMB Project Board Mother Board

J7, J8 and J9 serial communication port connectors: A female db-9 connector allows the PBMB to be connected directly to a PC Comm Port. This connector is already supplied (J7). In case the user wants to tap into the signals before they are processed by the RS-232 line driver, J8 is a good access point. It should be noted that not all the 9 pins on the serial communication port are connected through the RS-232 line driver. Also, J8 pads are at RS-232 logic level (from -15V for high to 15V for low). If the remaining lines are to be used, another line driver would have to be interfaced. However, this is not commonly the case.

J9 is the output of the RS-232 line driver. This signals carry the serial communication with a TTL logic level.

The pinout is shown below.

